

HOMEDICS®

LEADERS IN HOME ENVIRONMENT™



PLEASE TAKE A
MOMENT NOW
REGISTER YOUR PRODUCT AT:

www.homedics.com/register

Your valuable input regarding this product will help us create the products you will want in the future.

TOTALCLEAN™ AIRPURIFIER

INSTRUCTION MANUAL AND WARRANTY INFORMATION

TWO YEAR LIMITED WARRANTY

IMPORTANT SAFETY INSTRUCTIONS:

WHEN USING ELECTRICAL PRODUCTS, ESPECIALLY WHEN CHILDREN ARE PRESENT, BASIC SAFETY PRECAUTIONS SHOULD ALWAYS BE FOLLOWED, INCLUDING THE FOLLOWING:

READ ALL INSTRUCTIONS BEFORE USING.

DANGER — TO REDUCE THE RISK OF ELECTRIC SHOCK:

- Always unplug the air purifier from the electrical outlet immediately after using and before cleaning or replacing filters.
- Keep cord away from heated surfaces.
- Always place the air purifier on a firm, level surface.
- Always place the air purifier at least six (6) inches away from walls and three (3) feet from heat sources such as stoves, radiators, or heaters.
- DO NOT reach for an appliance that has fallen into water. Unplug it immediately.
- DO NOT place or store appliance where it can fall or be pulled into a tub or sink.
- DO NOT place in or drop into water or other liquid.
- Keep dry - DO NOT operate in wet or moist conditions.
- Check your air purifier cord and plug connections. Faulty wall outlet connections or loose plugs can cause the outlet or plug to overheat. Be sure the plug fits tightly in the outlet.

NOTE: This appliance has a polarized plug (one blade is wider than the other). To reduce the risk of shock, this plug is intended to fit only one way in a polarized outlet. If the plug does not fit fully in the outlet, reverse the plug. If it still does not fit, contact a qualified electrician.

DO NOT attempt to defeat this safety feature. To do so could result in an electric shock hazard.

WARNING — TO REDUCE THE RISK OF BURNS, FIRE, ELECTRIC SHOCK OR INJURY TO PERSONS:

- Always unplug the air purifier when not in use.
- Do not operate the air purifier with a damaged cord or plug, or after the air purifier malfunctions, or has been dropped or damaged in any manner. Return to HoMedics Consumer Relations for examination, electrical or mechanical adjustment, or repair.
- This air purifier is not intended for use in bathroom, laundry areas and similar moist indoor locations.
- Do not run cord under carpeting. Do not cover cord with throw rugs, runners or similar coverings. Do not route cord under furniture or appliances. Arrange cord away from traffic areas where it can be tripped over.
- To disconnect the air purifier, first turn controls to the OFF position, then remove plug from outlet.
- Do not tilt or move the air purifier while it is in operation. Shut off and remove plug from outlet before moving.
- Do not insert or allow foreign objects to enter any ventilation or exhaust opening as this may cause an electric shock or fire, or damage the air purifier.
- Do not block air intakes or exhaust in any manner. Do not use on any soft surface, like a bed, where openings may become blocked.
- Use this air purifier only for its intended use as described in this manual. Any other use not recommended by the manufacturer may cause fire, electric shock, or injury to persons.
- **DO NOT** use outdoors.
- This product is intended for household use only.

SAVE THESE IMPORTANT INSTRUCTIONS FOR EASY REFERENCE

TOTALCLEAN™ AIR PURIFIER

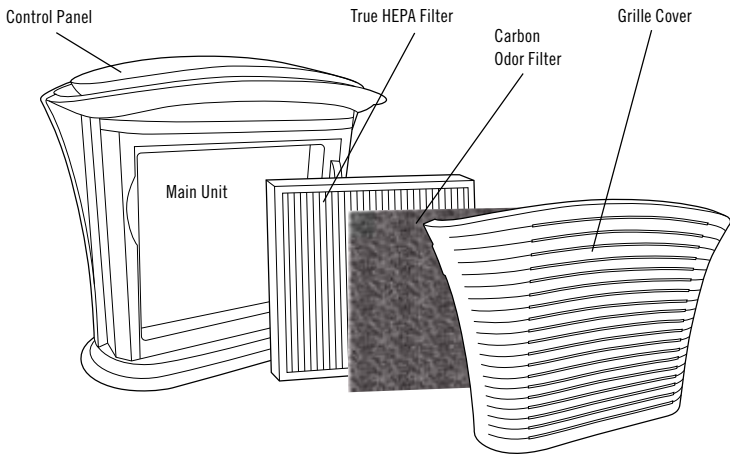

Replace Carbon Odor Filter Indicator Button

Replace True HEPA Filter Indicator Button

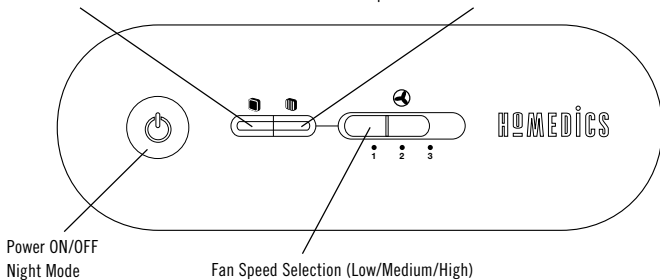

UNIQUE FEATURES & SPECIFICATIONS

TRUE HEPA FILTRATION

Removes up to 99.97% of airborne particles as small as 0.3 microns such as allergens, pollen, dust, germs, pet dander, odor, mold spores and smoke.

CARBON ODOR FILTER

Reduces household odors and captures large particles.

3 SPEEDS

Low, medium and high speeds.

NIGHT MODE

Turns off the display light while air purifier continues to operate.

REPLACE FILTER INDICATORS

Illuminates when it is time to replace the True HEPA or Carbon Odor Filter.

SUGGESTED ROOM SIZE

114 FT² / 10.6 M². Portable air purifiers will be more effective in rooms where all the doors and windows are closed.

AIR CHANGES PER HOUR

This air purifier will purify the air in a 114 FT² / 10.6 M² room (assuming an 8 FT / 2.43 M ceiling) 4.8 times per hour on high speed in a closed room.

HOW TO USE

BEFORE TURNING THE UNIT ON

- Take the air purifier out of the box and remove the clear protective plastic bag.
- Place the air purifier on a firm level surface.
- Locate the Carbon Odor Filter inside the box and remove the protective plastic bag.
- Install the Carbon Odor Filter and make sure the True HEPA filter is firmly in place.

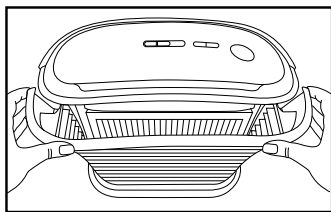

1. Open the back grille by pulling on the tabs on either side of the top of the grille cover.

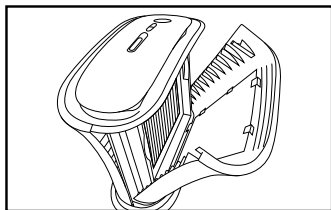

2. Open the cover outward until the tabs at the bottom of the grille cover easily slide away from the unit.

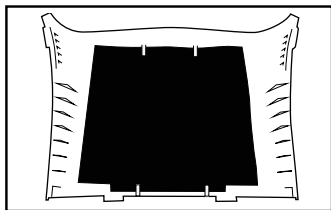

3. The top of the Carbon Odor Filter has 2 slots for installation. Hang the Carbon Odor Filter on the top tabs on the inside of the grille cover and secure under the bottom tabs.

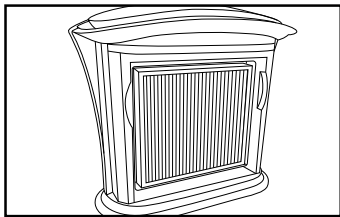

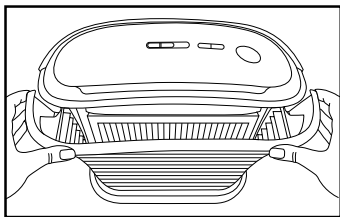

4. The True HEPA Filter will be resting inside the unit. Make sure the filter is firmly seated inside the unit with the Air Flow arrows pointing toward the inside of the air purifier.





5. Place the tabs at the bottom of the grille cover into the base of the unit. Gently push the grille cover back into place until you hear a click sound indicating that the grille cover is firmly latched. Plug the power cord into a standard AC outlet.

1. ON/OFF AND FAN SPEED SETTINGS

- To turn the air purifier on, press the ON/OFF  button. When the air purifier is on, the ON/OFF button will illuminate and the air purifier will start to operate.
- To activate NIGHT MODE and turn the air purifier display lights off, press the ON/OFF  button a second time

NOTE: Night mode can only be activated when the air purifier is powered on.

- To turn the air purifier display lights off, press the ON/OFF  button a second time.
- To turn the air purifier off, Press the ON/OFF  button a third time.
- This air purifier has 3 fan speed settings: LOW (1), MEDIUM (2), and HIGH (3). The higher the fan speed setting, the faster the air will be purified. To select or change fan speed, slide the FAN SPEED  Control until desired speed is reached.

FILTER REPLACEMENT

REPLACE CARBON ODOR FILTER INDICATOR BUTTON

The Replace Carbon Odor Filter Indicator illuminates when it is time to replace the Carbon Odor Filter based on the air purifier's hours of use.

REPLACE TRUE HEPA FILTER INDICATOR BUTTON

The Replace True HEPA Filter Indicator illuminates when it is time to replace the True HEPA Filter based on the air purifier's hours of use.

FILTER REPLACEMENT

It is recommended to check the filters on occasion if used to remove stronger odors or under heavy pollen conditions.

REPLACING THE CARBON ODOR FILTER

For optimal performance, replace every 3-months under normal usage conditions. Once the Carbon Odor Filter has been replaced, press and hold the Replace Carbon Odor Filter Button for 3-seconds to reset the indicator.

To purchase genuine HoMedics replacement Carbon Odor Filters, model AP-15CRF, go back to your retailer where you purchased your air purifier, or visit (US) www.homedics.com, (CAN) www.homedics.ca

REPLACING THE TRUE HEPA FILTER

For optimal performance, replace every 12-months under normal usage conditions. Once the True HEPA Filter has been replaced, press and hold the Replace True HEPA Filter Button for 3-seconds to reset the indicator.

To purchase genuine HoMedics replacement True HEPA Filters, model AF-10FL, go back to your retailer where you purchased your air purifier, or visit (US) www.homedics.com, (CAN) www.homedics.ca

CLEANING AND MAINTENANCE

FOR BEST PERFORMANCE, WE RECOMMEND:

- NEVER use water or any household cleaners or detergents to clean the True HEPA Filter or Carbon Odor Filter.
- Clean off the outside of the unit with a dry cloth once a month.
- NEVER use water, wax, polish, or any chemical solution to clean the outside of the unit.
- Clean off the grille cover using a damp cloth or the brush attachment of your vacuum once a month.
- Replace the Carbon Odor Filter every 3 months under normal usage conditions.
- Replace the True HEPA Filter every 12 months under normal usage conditions.
- Always use genuine HoMedics replacement filters for optimal performance.



This product earned the ENERGY STAR by meeting strict energy efficiency guidelines set by the US EPA. US EPA does not endorse any manufacturer claims of healthier indoor air from the use of this product. The energy efficiency of this ENERGY STAR qualified model is measured based on a ratio between the model's CADR for Dust and the electrical energy it consumes, or CADR/Watt.

TROUBLESHOOTING

PROBLEM	POSSIBLE CAUSE	SOLUTION
Unit will not operate	<ul style="list-style-type: none">• Unit is not plugged in• No power to unit	<ul style="list-style-type: none">• Plug unit in• Press the ON/OFF button to turn the power on• Check circuits, fuses, try a different outlet
Reduced airflow or poor filtering	<ul style="list-style-type: none">• The back grille may be blocked• True HEPA Filter may be clogged• Carbon Odor Filter may be clogged	<ul style="list-style-type: none">• Check to make sure nothing is blocking the back grille and air outlet• Replace the filter
Excessive noise	<ul style="list-style-type: none">• The unit is not level	<ul style="list-style-type: none">• Place the unit on a flat, level surface
Replace filter light remains lit after filter replacement	<ul style="list-style-type: none">• The appropriate replace filter indicator needs to be reset	<ul style="list-style-type: none">• Press and hold the appropriate replace filter button for 3 seconds
The air purifier seems to be producing odors	<ul style="list-style-type: none">• The filters need replacing	<ul style="list-style-type: none">• Replace the filters as needed



LEADERS IN HOME ENVIRONMENT™

LIMITED TWO YEAR WARRANTY

HoMedics sells its products with the intent that they are free of defects in manufacture and workmanship for a period of two years from the date of original purchase, except as noted below. HoMedics warrants that its products will be free of defects in material and workmanship under normal use and service. This warranty extends only to consumers and does not extend to Retailers.

To obtain warranty service on your HoMedics product, contact a consumer relations representative for assistance. Please make sure to have the model number of the product available.

HoMedics does not authorize anyone, including, but not limited to, Retailers, the subsequent consumer purchaser of the product from a Retailer or remote purchasers, to obligate HoMedics in any way beyond the terms set forth herein. This warranty does not cover damage caused by misuse or abuse; accident; the attachment of any unauthorized accessory; alteration to the product; improper installation; unauthorized repairs or modifications; improper use of electrical/power supply; loss of power; dropped product; malfunction or damage of an operating part from failure to provide manufacturer's recommended maintenance; transportation damage; theft; neglect; vandalism; or environmental conditions; loss of use during the period the product is at a repair facility or otherwise awaiting parts or repair; or any other conditions whatsoever that are beyond the control of HoMedics.

This warranty is effective only if the product is purchased and operated in the country in which the product is purchased. A product that requires modifications or adoption to enable it to operate in any other country than the country for which it was designed, manufactured, approved and/or authorized, or repair of products damaged by these modifications is not covered under this warranty.

THE WARRANTY PROVIDED HEREIN SHALL BE THE SOLE AND EXCLUSIVE WARRANTY. THERE SHALL BE NO OTHER WARRANTIES EXPRESS OR IMPLIED INCLUDING ANY IMPLIED WARRANTY OF MERCHANTABILITY OR FITNESS OR ANY OTHER OBLIGATION ON THE PART OF THE COMPANY WITH RESPECT TO PRODUCTS COVERED BY THIS WARRANTY. HOMEDICS SHALL HAVE NO LIABILITY FOR ANY INCIDENTAL, CONSEQUENTIAL OR SPECIAL DAMAGES. IN NO EVENT SHALL THIS WARRANTY REQUIRE MORE THAN THE REPAIR OR REPLACEMENT OF ANY PART OR PARTS WHICH ARE FOUND TO BE DEFECTIVE WITHIN THE EFFECTIVE PERIOD OF THE WARRANTY. NO REFUNDS WILL BE GIVEN. IF REPLACEMENT PARTS FOR DEFECTIVE MATERIALS ARE NOT AVAILABLE, HOMEDICS RESERVES THE RIGHT TO MAKE PRODUCT SUBSTITUTIONS IN LIEU OF REPAIR OR REPLACEMENT.

This warranty does not extend to the purchase of opened, used, repaired, repackaged and/or resealed products, including but not limited to sale of such products on Internet auction sites and/or sales of such products by surplus or bulk resellers. Any and all warranties or guarantees shall immediately cease and terminate as to any products or parts thereof which are repaired, replaced, altered, or modified, without the prior express and written consent of HoMedics.

This warranty provides you with specific legal rights. You may have additional rights which may vary from state to state and country to country. Because of individual state and country regulations, some of the above limitations and exclusions may not apply to you.

For more information regarding our product line in the USA, please visit: www.homedics.com.

For Canada, please visit: www.homedics.ca.

FOR SERVICE IN THE USA:

Email: cservice@homedics.com

Monday-Friday 8:30am-7:00pm EST

1.800.466.3342

FOR SERVICE IN CANADA:

Email: cservice@homedicsgroup.ca

Monday-Friday 8:30am-5:00pm EST

1.888.225.7378