

READ AND SAVE THESE INSTRUCTIONS

Before turning the unit on:

- Take the air purifier out of the box and remove the clear protective plastic bag.
- Place the air purifier on a firm, level surface.
- Plug the power cord into a household electrical outlet.

HOW TO USE

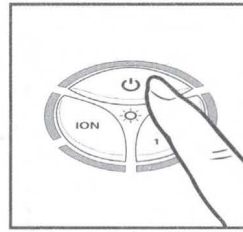
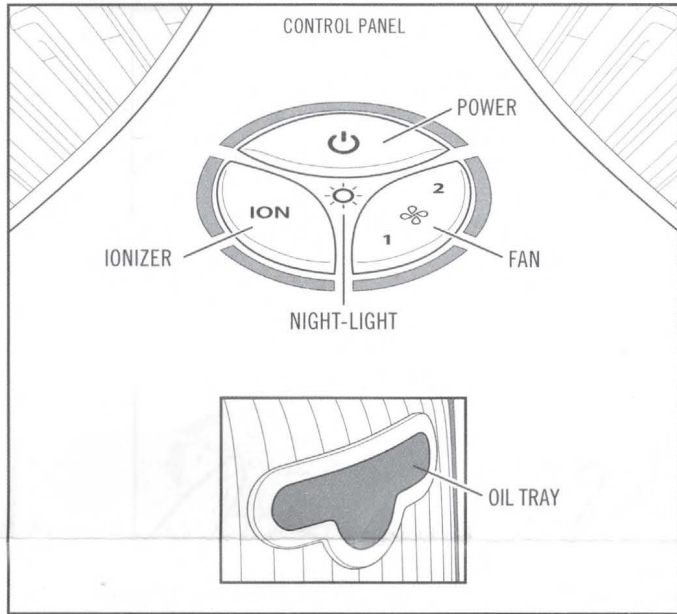

1. Press the power button to turn the air purifier on/off.

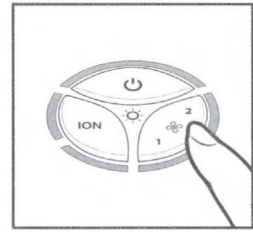

2. Press the fan button to select desired fan speed.

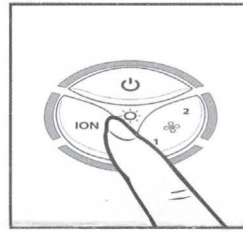

3. Press the ionizer button to turn the ionizer on/off.

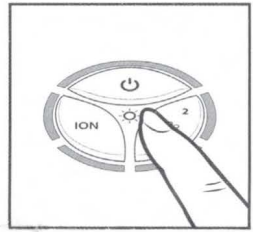

4. Press the night-light button to turn the night-light on/off.

ADDING ESSENTIAL OILS

WARNING: Putting oil anywhere but the oil tray will damage the air purifier.

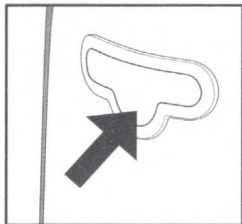

1. The oil tray is located on the side of the air purifier.

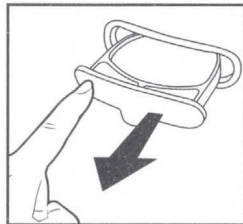

2. Push to open and remove the tray.

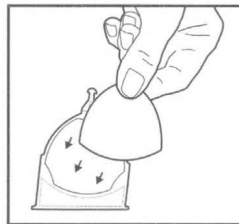

3. Place 1 aroma pad (3 included) into the oil tray.

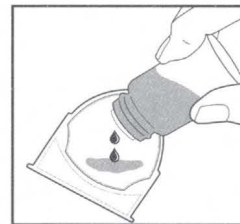

4. Add 5-7 drops of essential oil to the pad. You may use more or less depending on personal preference. **WARNING: Only place essential oil on the pad and NOT directly into the tray.**

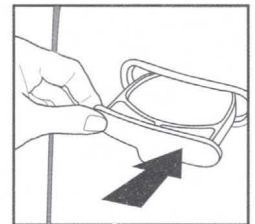

5. Place the oil tray back in its compartment and push to close. The scent will start automatically when the air purifier is turned on.

ARE ESSENTIAL OILS SAFE TO USE AROUND PETS?

We should always exercise caution when using essential oils around our pets. Keep all essential oil and aromatherapy products (like diffusers) out of reach of pets. Keep open bottles away from pets to avoid internal consumption. We do not recommend the topical use of essential oils on pets, as they have a strong sense of smell and cannot get rid of the oil if they don't like it or it is disturbing them. When diffusing essential oils around pets, always diffuse in a well-ventilated area and leave an option for them to remove themselves from the space, such as leaving a door open. Every animal is different, so carefully observe how each animal responds when introducing an essential oil for the first time. If irritation occurs, discontinue the use of the essential oil. We recommend seeking medical attention if ingestion of essential oil occurs.

HOMEDICS

LEADERS IN HOME ENVIRONMENT™

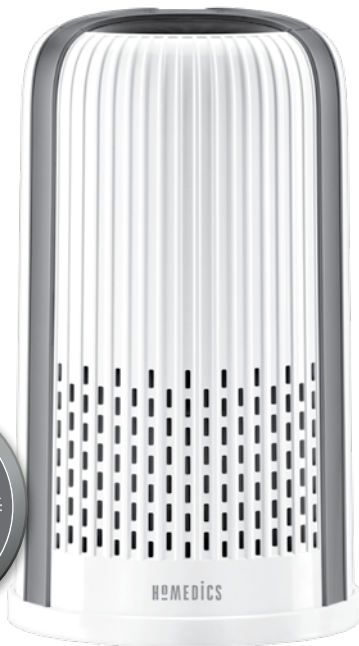

TOTALCLEAN[®] 4IN1AIRPURIFIER

INSTRUCTION MANUAL AND WARRANTY INFORMATION

3-YEAR LIMITED WARRANTY

AP-T10

IMPORTANT SAFETY INSTRUCTIONS:

WHEN USING ELECTRICAL PRODUCTS, ESPECIALLY WHEN CHILDREN ARE PRESENT, BASIC SAFETY PRECAUTIONS SHOULD ALWAYS BE FOLLOWED, INCLUDING THE FOLLOWING:

READ ALL INSTRUCTIONS BEFORE USING.

DANGER — TO REDUCE THE RISK OF ELECTRIC SHOCK:

- Always unplug the air purifier from the electrical outlet immediately after using and before cleaning or replacing filters.
- Keep cord away from heated surfaces.
- Always place the air purifier on a firm, level surface.
- Always place the air purifier at least 6 inches away from walls and 3 feet from heat sources, such as stoves, radiators, or heaters.
- DO NOT reach for an appliance that has fallen into water. Unplug it immediately.
- DO NOT place or store appliance where it can fall or be pulled into a tub or sink.
- DO NOT place in or drop into water or other liquid.
- Keep dry — DO NOT operate in wet or moist conditions.
- Check your air purifier cord and plug connections. Faulty wall outlet connections or loose plugs can cause the outlet or plug to overheat. Be sure the plug fits tightly in the outlet.

This product complies with the maximum allowable concentration of ozone of 0.050 parts per million by volume (ppmv) in a 24-hour period. The Health Canada Guideline 2010 recommends that the maximum exposure limit, based on an averaging time of 8 hours, is 0.020 ppmv or less when tested in a sealed, controlled room approximately 30 m³.

NOTE: This appliance has a polarized plug (one blade is wider than the other). To reduce the risk of shock, this plug is intended to fit only one way in a polarized outlet. If the plug does not fit fully in the outlet, reverse the plug. If it still does not fit, contact a qualified electrician.

CAUTION: DO NOT attempt to defeat this safety feature. To do so could result in an electric shock hazard.

WARNING — TO REDUCE THE RISK OF BURNS, FIRE, ELECTRIC SHOCK, OR INJURY TO PERSONS:

- Always unplug the air purifier when not in use.
- DO NOT operate the air purifier with a damaged cord or plug, or after the air purifier malfunctions, or has been dropped or damaged in any manner. Return to a HoMedics Service Center for examination, electrical or mechanical adjustment, or repair.
- This air purifier is not intended for use in bathrooms, laundry areas, and similar moist indoor locations.
- DO NOT run cord under carpeting. Do not cover cord with throw rugs, runners, or similar coverings. Do not route cord under furniture or appliances. Arrange cord away from traffic areas where it can be tripped over.
- To disconnect the air purifier, first turn controls to the off position, then remove plug from outlet.
- DO NOT tilt or move the air purifier while it is in operation. Shut off and remove plug from outlet before moving.
- DO NOT insert or allow foreign objects to enter any ventilation or exhaust opening as this may cause an electric shock or fire, or damage the air purifier.
- DO NOT block air intakes or exhaust in any manner. Do not use on any soft surface, like a bed, where openings may become blocked.
- Use this air purifier only for its intended use as described in this manual. Any other use not recommended by the manufacturer may cause fire, electric shock, or injury to persons.
- DO NOT use outdoors.
- This product is intended for household use only.

SAVE THESE IMPORTANT INSTRUCTIONS FOR EASY REFERENCE.

UNIQUE FEATURES & SPECIFICATIONS

ALL-IN-ONE HEPA-TYPE FILTRATION SYSTEM

- **HEPA-TYPE FILTRATION**

Removes up to 99% of airborne particles as small as 0.3 microns, such as allergens, pollen, dust, germs, pet dander, odor, mold spores, and smoke from air that passes through the filter.

- **CARBON ODOR FILTRATION**

Reduces household odors and VOCs (volatile organic compounds/gases) as shown by independent laboratory testing.

- **PREFILTER**

Captures large particles.

IONIZER WITH ON/OFF

When on, assists in the air purification process.

2 SPEEDS

Low and high.

NIGHT-LIGHT

Built-in night-light with on/off.

REPLACE FILTER INDICATOR

Illuminates when it is time to replace the filter.

SUGGESTED ROOM SIZE

90 FT²/8.3 M². Portable air purifiers will be more effective in a closed room.

AIR CHANGES PER HOUR

This air purifier will change the air in a 291 FT²/27 M² closed room every hour on high speed assuming an 8 FT/2.43 M ceiling.

OIL TRAY

Includes 3 essential oil pads. Use with essential oil (not included) to deliver scent into the air.

CONTROL PANEL (DETAIL)

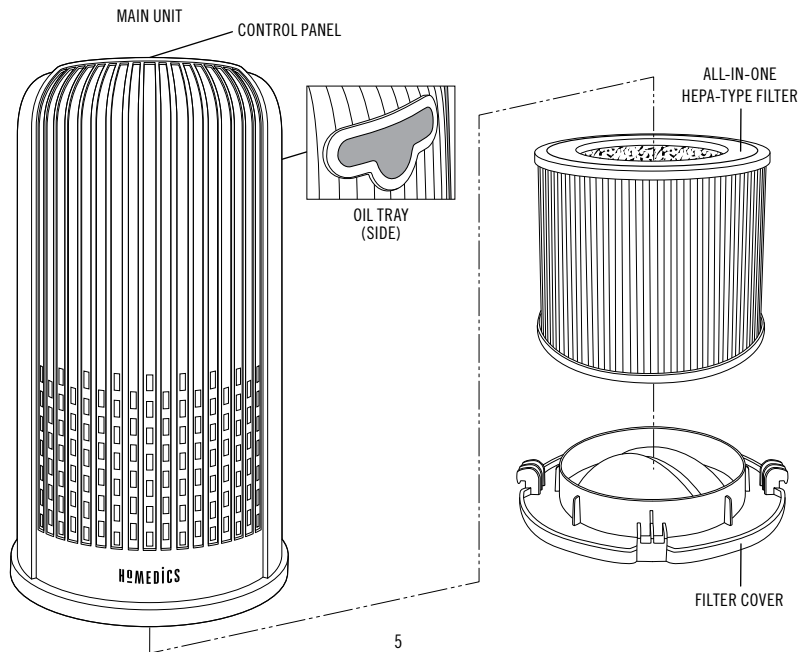
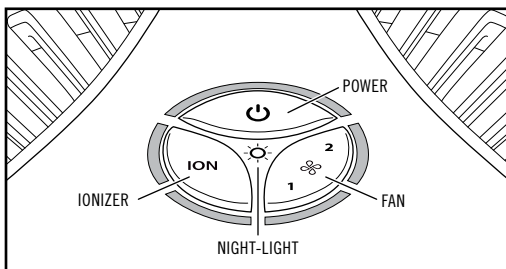



HOW TO USE

BEFORE TURNING THE UNIT ON

- Take the air purifier out of the box and remove the clear protective plastic bag.
- Place the air purifier on a firm, level surface.
- Plug the power cord into a household electrical outlet.

POWER BUTTON AND FAN SPEED SETTINGS

- To turn the air purifier on, press the power  button.
- This air purifier has 2 fan speed settings: low (1) and high (2). The higher the fan speed setting, the faster the air will be purified. To select or change fan speed, press the fan speed  button until the desired setting is reached.

IONIZER SETTING WITH ON/OFF

Ion particles have a negative charge that attaches to airborne particles, making them easier to be captured by the filtration system. Press the ionizer **ION** button to turn the ionizer on. The blue light will glow to indicate the ionizer is in use. Press the ionizer **ION** button again to turn the ionizer off.

NOTE: Dust particles may accumulate on surfaces around the air purifier when the ionizer is in use. These dust particles can be vacuumed or wiped away with a soft, damp cloth.

NOTE: You may hear occasional popping sounds when the ionizer is used. This is normal.

NOTE: The ionizer produces less ozone than the UL-established limits of 0.05 ppm. Ozone may be harmful around birds and small pets. To prevent ozone buildup, use the ionizer feature in a well-ventilated area.

NIGHT-LIGHT

The nightlight has 3 options. Press the night-light button once to turn the blue night-light on. Press again to turn the blue night-light and display lights off. Press a third time to turn the display lights on.

OIL TRAY

Use essential oil (not included) to deliver scent into the air.

NOTE: For use with the included HoMedics essential oil pads only. Do not add essential oils anywhere else in the unit as it may cause damage.

NOTE: Do not leave a filled essential oil pad in the oil tray if it will be out of use for a long period of time.

ARE ESSENTIAL OILS SAFE TO USE AROUND PETS?

We should always exercise caution when using essential oils around our pets. Keep all essential oil and aromatherapy products (like diffusers) out of reach of pets. Keep open bottles away from pets to avoid internal consumption. We do not recommend the topical use of essential oils on pets, as they have a strong sense of smell and cannot get rid of the oil if they don't like it or it is disturbing them. When diffusing essential oils around pets, always diffuse in a well-ventilated area and leave an option for them to remove themselves from the space, such as leaving a door open. Every animal is different, so carefully observe how each animal responds when introducing an essential oil for the first time. If irritation occurs, discontinue the use of the essential oil. We recommend seeking medical attention if ingestion of essential oil occurs.

ADDING ESSENTIAL OILS

WARNING: PUTTING OIL ANYWHERE BUT THE OIL TRAY WILL DAMAGE THE AIR PURIFIER.

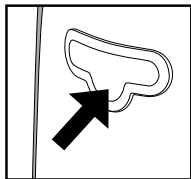

1. The oil tray is located on the side of the air purifier.

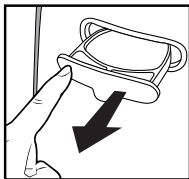

2. Push to open and remove the tray.

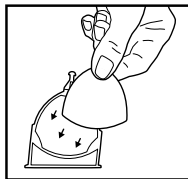

3. Place 1 aroma pad (3 included) into the oil tray.

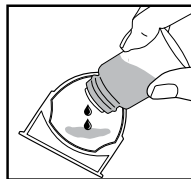

4. Add 5–7 drops of essential oil to the pad. You may use more or less depending on personal preference. **WARNING: Only place essential oil on the pad and NOT directly into the tray.**

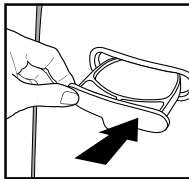

5. Place the oil tray back in its compartment and push to close. The scent will start automatically when the air purifier is turned on.

To purchase genuine HoMedics Replacement Essential Oil Pads, Model # UHE-PAD1, go to the retailer where you purchased your HoMedics TotalClean Air Purifier, or visit www.homedics.com (US), www.homedics.ca (CAN).

To purchase genuine HoMedics Essential Oils, go to the retailer where you purchased your HoMedics TotalClean Air Purifier, or visit www.homedics.com (US), www.homedics.ca (CAN).

FILTER REPLACEMENT

REPLACE FILTER NOTIFICATION

The power button will flash red when it is time to replace the HEPA-type filter based on the air purifier's hours of use.

REPLACING THE HEPA-TYPE FILTER

For optimal performance, replace every 12 months under normal usage conditions.

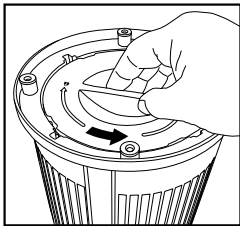

1. Unplug the air purifier and turn upside down. Turn the filter cover as indicated to remove.

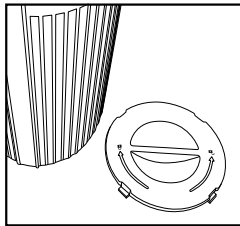

2. Remove the filter cover and set aside.

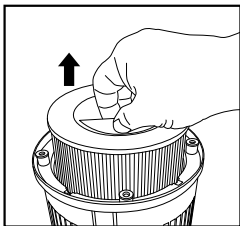

3. Pull to remove the old filter.

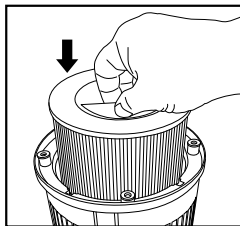

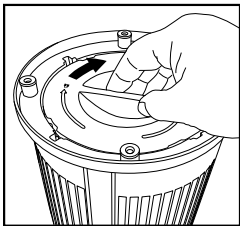

4. Slide the new HEPA-type filter into the filter cavity.

To purchase genuine HoMedics replacement HEPA-type filters, model AP-T10FL, go back to the retailer where you purchased your air purifier, or visit www.homedics.com (US), www.homedics.ca (CAN).

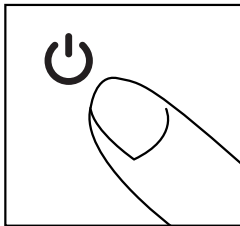

5. Reinstall the filter cover and turn to the right to lock in place.



6. Plug the power cord into a household electrical outlet. Turn the air purifier on. Press and hold the power  button for 3 seconds to reset the indicator.

CLEANING AND MAINTENANCE

CLEANING THE PREFILTER

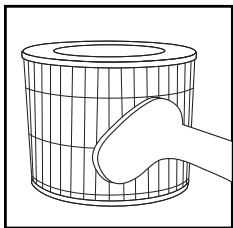

NOTE: For best performance, vacuum the prefilter once a month under normal usage.

1. Unplug the air purifier.
2. Remove the HEPA-type filter as described in the Replacing the HEPA-Type Filter section.
3. Vacuum the outside of the HEPA-type filter using the brush attachment of your vacuum cleaner, cleaning it thoroughly.
4. Place the HEPA-type filter back into the air purifier and close the filter cover.
5. Plug the power cord into a household electrical outlet.

TO CLEAN THE OIL TRAY

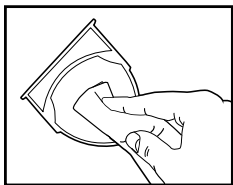

Open the oil tray and remove the pad. Essential oil pads should be changed when switching to a different essential oil scent. If continuing to use the same scent, set the essential oil pad aside for reuse. Wipe down the inside of the oil tray with a soft cloth. Place the essential oil pad back in the tray and close.

NOTE: Leave the essential oil pad out of the oil tray when storing.

FOR BEST PERFORMANCE:

- NEVER use water or any household cleaners or detergents to clean the HEPA-type filter.
- Clean off the outside of the unit with a soft, dry cloth as needed.
- NEVER use water, wax, polish, or any chemical solution to clean the outside of the unit.
- Clean off the grille using a soft, damp cloth or the brush attachment of your vacuum as needed.
- Vacuum the prefilter monthly under normal usage conditions.
- Replace the HEPA-type filter every 12 months under normal usage conditions.
- Always use a genuine HoMedics replacement filter for optimal performance.



This product earned the ENERGY STAR label by meeting strict energy efficiency guidelines set by the U.S. EPA. Room air cleaners have demonstrated the potential for improving air quality and providing health benefits. EPA does not endorse manufacturer claims regarding the degree to which a specific product will produce healthier indoor air. The energy efficiency of this ENERGY STAR certified model is measured based on a ratio between the model's CADR for Smoke and the electrical energy it consumes, or CADR/Watt.

TROUBLESHOOTING

PROBLEM	POSSIBLE CAUSE	SOLUTION
Unit will not operate	<ul style="list-style-type: none">• Unit is not plugged in• Power button not pressed• No power to unit	<ul style="list-style-type: none">• Plug unit in• Press the power button to turn the power on• Check circuits, fuses, try a different outlet
Reduced airflow	<ul style="list-style-type: none">• The grille may be blocked• Prefilter needs to be vacuumed• The HEPA-type filter needs to be replaced	<ul style="list-style-type: none">• Check to make sure nothing is blocking the grille and air outlet• Vacuum the prefilter with the brush attachment of your vacuum cleaner• Replace the HEPA-type filter
Reduced odor removal	<ul style="list-style-type: none">• The HEPA-type filter needs to be replaced	<ul style="list-style-type: none">• Replace the HEPA-type filter
Excessive noise	<ul style="list-style-type: none">• The unit is not level	<ul style="list-style-type: none">• Place the unit on a flat, level surface
Power button flashes red after filter replacement	<ul style="list-style-type: none">• The replace filter indicator needs to be reset	<ul style="list-style-type: none">• Press and hold the power button for 3 seconds until the flashing power light turns off

LIMITED 3-YEAR WARRANTY

HoMedics sells its products with the intent that they are free of defects in manufacture and workmanship for a period of 3 years from the date of original purchase, except as noted below. HoMedics warrants that its products will be free of defects in material and workmanship under normal use and service. This warranty extends only to consumers and does not extend to Retailers.

To obtain warranty service on your HoMedics product, contact a Consumer Relations representative for assistance. Please make sure to have the model number of the product available.

HoMedics does not authorize anyone, including but not limited to Retailers, the subsequent consumer purchaser of the product from a Retailer, or remote purchasers, to obligate HoMedics in any way beyond the terms set forth herein. This warranty does not cover damage caused by misuse or abuse; accident; the attachment of any unauthorized accessory; alteration to the product; improper installation; unauthorized repairs or modifications; improper use of electrical/power supply; loss of power; dropped product; malfunction or damage of an operating part from failure to provide manufacturer's recommended maintenance; transportation damage; theft; neglect; vandalism; or environmental conditions; loss of use during the period the product is at a repair facility or otherwise awaiting parts or repair; or any other conditions whatsoever that are beyond the control of HoMedics.

This warranty is effective only if the product is purchased and operated in the country in which the product is purchased. A product that requires modifications or adoption to enable it to operate in any other country than the country for which it was designed, manufactured, approved, and/or authorized, or repair of products damaged by these modifications is not covered under this warranty.

THE WARRANTY PROVIDED HEREIN SHALL BE THE SOLE AND EXCLUSIVE WARRANTY. THERE SHALL BE NO OTHER WARRANTIES EXPRESS OR IMPLIED, INCLUDING ANY IMPLIED WARRANTY OF MERCHANTABILITY OR FITNESS OR ANY OTHER OBLIGATION ON THE PART OF THE COMPANY WITH RESPECT TO PRODUCTS COVERED BY THIS WARRANTY. HOMEDICS SHALL HAVE NO LIABILITY FOR ANY INCIDENTAL, CONSEQUENTIAL, OR SPECIAL DAMAGES. IN NO EVENT SHALL THIS WARRANTY REQUIRE MORE THAN THE REPAIR OR REPLACEMENT OF ANY PART OR PARTS THAT ARE FOUND TO BE DEFECTIVE WITHIN THE EFFECTIVE PERIOD OF THE WARRANTY. NO REFUNDS WILL BE GIVEN. IF REPLACEMENT PARTS FOR DEFECTIVE MATERIALS ARE NOT AVAILABLE, HOMEDICS RESERVES THE RIGHT TO MAKE PRODUCT SUBSTITUTIONS IN LIEU OF REPAIR OR REPLACEMENT.

This warranty does not extend to the purchase of opened, used, repaired, repackaged, and/or resealed products, including but not limited to sale of such products on internet auction sites and/or sales of such products by surplus or bulk resellers. Any and all warranties or guarantees shall immediately cease and terminate as to any products or parts thereof that are repaired, replaced, altered, or modified, without the prior express and written consent of HoMedics.

This warranty provides you with specific legal rights. You may have additional rights that may vary from country to country. Because of individual country regulations, some of the above limitations and exclusions may not apply to you.

For more information regarding our product line in the USA, please visit www.homedics.com. For Canada, please visit www.homedics.ca.

FOR SERVICE IN THE USA

cservice@homedics.com

8:30am–7:00pm EST Monday–Friday

1-800-466-3342

FOR SERVICE IN CANADA

cservice@homedicsgroup.ca

8:30am–5:00pm EST Monday–Friday

1-888-225-7378

STOP

Need help? Call us. We're here to help.

Consumer relations representatives are ready to help you with any questions you may have about this product, so that you can begin enjoying its benefits as soon as possible.

IF YOU HAVE ANY QUESTIONS OR CONCERNS, OR HAVE A CHALLENGE USING THIS PRODUCT, PLEASE CALL US BEFORE YOU CONSIDER RETURNING THE PRODUCT TO THE RETAILER.

**Besoin d'aide?
Appelez-nous.**

ARRÊT

**Nous nous ferons
un plaisir
de vous aider.**

Les représentants de notre service des relations clientèle sont à votre disposition pour toute question concernant ce produit, afin que vous puissiez commencer à profiter de ses avantages dès que possible.

POUR TOUTE QUESTION OU PRÉOCCUPATION, OU SI VOUS AVEZ DES DIFFICULTÉS À UTILISER CE PRODUIT, VEUILLEZ NOUS APPELER AVANT D'ENVISAGER DE RETOURNER LE PRODUIT AU DÉTAILLANT.

**¿Necesita ayuda?
Llámenos.**

PARE

**Estamos aquí
para ayudar.**

Los representantes de relaciones con el consumidor están preparados para responder cualquier pregunta que usted pueda tener sobre este producto, de modo que pueda comenzar a disfrutar de los beneficios lo antes posible.

SI TIENE DUDAS O PREGUNTAS, O SI TIENE ALGÚN PROBLEMA AL USAR ESTE PRODUCTO, LLÁMENOS ANTES DE PENSAR EN LA POSIBILIDAD DE DEVOLVERLO A LA TIENDA MINORISTA.

Need help? Call us. We're here to help.

**Besoin d'aide? Appelez-nous.
Nous nous ferons un plaisir de vous aider.**

**¿Necesita ayuda? Llámenos.
Estamos aquí para ayudar.**

**1.800.466.3342
(USA) (É.-U.) (EE.UU.)**

**1.888.225.7378
(CAN)**

**Distributed by
Distribué par
Distribuido por**

HOMEDICS®